

RECOMMENDED PROCEDURE FOR INSTALLATION OF DRILLCO MAXI-BOLT ANCHORS

Revision 0588VO

By

Drillco National Group
P. O. Box 2182
Long Island City, NY 11102
Telephone: (800) 391-0052
www.drillcogroup.com
techsupport@drillcogroup.com

1.0 GENERAL REQUIREMENTS

1.1 This procedure specifies drill sizes, minimum hole depths, embedment dimensions, and installation requirements for Maxi-Bolt anchors as manufactured by Drillco Devices Ltd.

1.2 Personnel assigned to install Maxi-Bolt anchors should receive training from a Drillco Qualified Instructor before proceeding with work.

2.0 DRILLING HOLES

2.1 Locating Holes

2.1.1 Mark placement of anchor(s) on concrete in accordance with job site specifications.

2.2 Drilling Primary Hole

2.2.1 Holes shall be drilled with a Drillco carbide percussion drill bit, Drillco "Rebar Eater" bit, or Drillco diamond core bit.

2.2.2 Drill diameter is specified in Table I and is presented solely for informational purposes.

a. A Drillco DBGNG (Drill Bit Go/No Go Gauge) shall be used to determine acceptability of the primary hole bit.

b. This procedure does not specify a minimum primary hole bit diameter.

2.2.3 Drill hole to depth specified in Table I.

- a. Hole depth shall not be less than hole depth specified.
- b. Hole may be drilled to any depth greater than hole depth specified.

2.2.4 Holes shall be drilled within 6 degrees of perpendicular to the nominal concrete surface.

- a. The use of a guide, level, or square is recommended.

2.2.5 Clean hole of concrete dust and debris.

2.2.6 Measure depth of hole to ensure that minimum hole depth has been achieved.

2.3 Relocating Hole

2.3.1 If anchor must be relocated and a new hole drilled, the old hole shall be repaired in accordance with contract drawings or specifications.

2.4 Drilling Undercut in Primary Hole

2.4.1 Undercut in primary hole shall be drilled only with a Drillco Undercutting Tool.

2.4.2 Tool diameter A and cutter diameter B (diameter with cutter(s) in fully opened position) are specified in Table II (for informational purposes only) and illustrated in Figures 1 and 1A.

- a. A Drillco UTGNG (Undercutting Tool Go/No Go Gauge) shall be used to determine that the cutter blades are within the tolerances specified in Table II.

2.4.3 The depth at which the undercut is formed is controlled by the position of tool's bearing sleeve (C in Figures 1 and 1A). To achieve the correct undercut depth:

- a. Set tool's bearing sleeve so that Dimension F in Figure 1 or 1A corresponds to the specified embedment depth of the anchor being installed.
- b. When anchors are to be installed prior to placement of attachment, the bottom of the bearing sleeve should be placed in contact with the surface of the concrete.
- c. When anchors are being installed through an "in place" attachment, the bearing sleeve should be placed in contact with the surface of the attachment. Furthermore, the attachment should be in contact with the nominal surface of concrete.

2.4.4 With the bearing sleeve in contact with the surface of the concrete or attachment, but with no pressure applied to the drill, start drill motor.

2.4.5 With drill motor running apply a steady pressure on the drill and observe the location of Pin D (Figures 1 and 1A) in Slot E.

2.4.6 When Pin D is in contact with bottom of Slot E (as shown in Figures 1 and 1A) the undercut is

complete. To verify this it may be necessary to stop the drill motor and observe pin location.

2.4.7 After the undercut has been completed, stop the drill motor and remove the tool from the hole. Inspect tool cutter(s) to ensure that they have not been damaged during the drilling operation.

2.4.8 Clean the hole of concrete dust and debris.

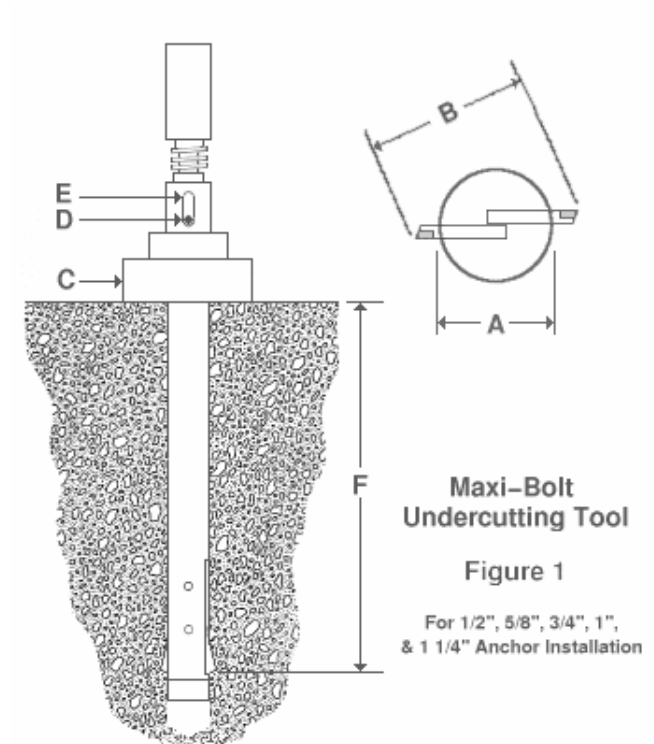

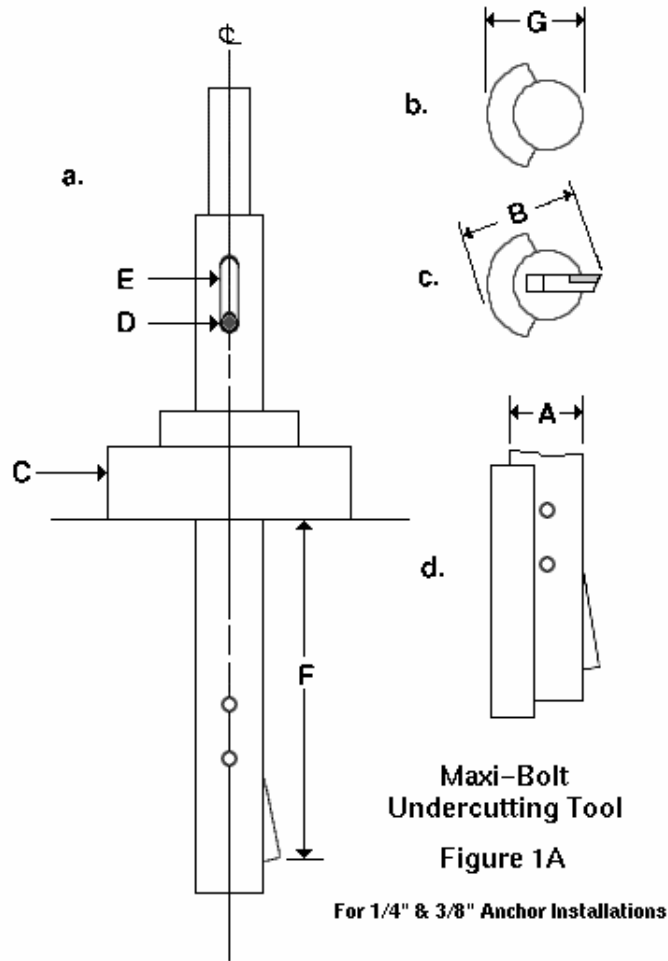

3.0 INSTALLING ANCHORS

3.1 Examine Assembled Anchor

3.1.1 Check to ensure that all components are present and that the bolt is correctly assembled. See Figure 2.

3.1.2 No modification to the anchor shall be permitted.

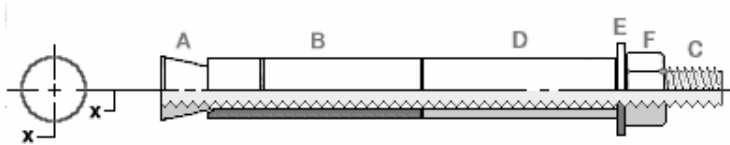

Drillco Maxi-Bolt
Figure 2

High Strength Steel Maxi-Bolts
ASTM A193 Grade B7

A.	Conical Nut	ASTM A193 Grade B7	UNC Series Class 2B fit for 1/4", 3/8", 1/2", 5/8", 3/4", and 1" UN 8 Pitch Series Class 2B fit for 1 1/4"
B.	Expansion Sleeve	ASTM A513 Type 5	ERW DOM Tubing
C.	Threaded Stud Bolt	ASTM A193 Grade B7	UNC Series Class 2B fit for 1/4", 3/8", 1/2", 5/8", 3/4", and 1" UN 8 Pitch Series Class 2B fit for 1 1/4"
D.	Distance Tube	ASTM A513 Type 5	ERW DOM Tubing
E.	Washer	ASTM A325	Hardened Round Flat Washer
F.	Heavy Hex Nut	ASTM A194 Grade 2H	UNC Series Class 2B fit for 1/4", 3/8", 1/2", 5/8", 3/4", and 1" UN 8 Pitch Series Class 2B fit for 1 1/4"

Mild Steel Maxi-Bolts
ASTM A36

A.	Conical Nut	ASTM A193 Grade B7	UNC Series Class 2B fit for 1/4", 3/8", 1/2", 5/8", 3/4", and 1" UN 8 Pitch Series Class 2B fit for 1 1/4"
B.	Expansion Sleeve	ASTM A513 Type 5	ERW DOM Tubing
C.	Threaded Stud Bolt	ASTM A36	UNC Series Class 2B fit for 1/4", 3/8", 1/2", 5/8", 3/4", and 1" UN 8 Pitch Series Class 2B fit for 1 1/4"
D.	Distance Tube	ASTM A513 Type 5	ERW DOM Tubing
E.	Washer	ASTM A325	Hardened Round Flat Washer
F.	Heavy Hex Nut	ASTM A194 Grade 2H	UNC Series Class 2B fit for 1/4", 3/8", 1/2", 5/8", 3/4", and 1" UN 8 Pitch Series Class 2B fit for 1 1/4"

Stainless Steel Maxi-Bolts
ASTM A193 Grade B8 - Class 1 - Type 304

A.	Conical Nut	ASTM A193 Grade B8 Class 1	UNC Series Class 2B fit for 1/4", 3/8", 1/2", 5/8", 3/4", and 1" UN 8 Pitch Series Class 2B fit for 1 1/4"
B.	Expansion Sleeve	ASTM A213	ERW DOM Tubing
C.	Threaded Stud Bolt	ASTM A193 Grade B8 Class 1 fu = 75,000 psi fy = 30,000 psi	UNC Series Class 2B fit for 1/4", 3/8", 1/2", 5/8", 3/4", and 1" UN 8 Pitch Series Class 2B fit for 1 1/4"
D.	Distance Tube	ASTM A213	ERW DOM Tubing
E.	Washer	AISC 304	Hardened Round Flat Washer
F.	Heavy Hex Nut	ASTM A194 Grade B8	UNC Series Class 2B fit for 1/4", 3/8", 1/2", 5/8", 3/4", and 1" UN 8 Pitch Series Class 2B fit for 1 1/4"

Stainless Steel Maxi-Bolts
ASTM A193 Grade B8 - Class 2 - Type 304

A.	Conical Nut	1/2" and under ASTM A193 Grade B8 Class 2 5/8" and larger ASTM A564 Type 630	UNC Series Class 2B fit for 1/4", 3/8", 1/2", 5/8", 3/4", and 1" UN 8 Pitch Series Class 2B fit for 1 1/4"
B.	Expansion Sleeve	ASTM A213	ERW DOM Tubing
C.	Threaded Stud Bolt	ASTM A193 Grade B8 Class 2 3/4" and under fu = 125,000 psi fy = 100,000 psi 1" fu = 115,000 psi fy = 80,000 psi 1 1/4" fu = 105,000 psi fy = 65,000 psi	UNC Series Class 2B fit for 1/4", 3/8", 1/2", 5/8", 3/4", and 1" UN 8 Pitch Series Class 2B fit for 1 1/4"
D.	Distance Tube	ASTM A213	ERW DOM Tubing
E.	Washer	AISC 304	Hardened Round Flat Washer
F.	Heavy Hex Nut	ASTM A194 Grade B8 Strain Hardened	UNC Series Class 2B fit for 1/4", 3/8", 1/2", 5/8", 3/4", and 1" UN 8 Pitch Series Class 2B fit for 1 1/4"

Stainless Steel Maxi-Bolts
ASTM A193 Grade B8M - Class 1 - Type 316

A.	Conical Nut	ASTM A193 Grade B8M Class 1	UNC Series Class 2B fit for 1/4", 3/8", 1/2", 5/8", 3/4", and 1" UN 8 Pitch Series Class 2B fit for 1 1/4"
B.	Expansion Sleeve	ASTM A213	ERW DOM Tubing
C.	Threaded Stud Bolt	ASTM A193 Grade B8M Class 1 fu = 75,000 psi fy = 30,000 psi	UNC Series Class 2B fit for 1/4", 3/8", 1/2", 5/8", 3/4", and 1" UN 8 Pitch Series Class 2B fit for 1 1/4"
D.	Distance Tube	ASTM A213	ERW DOM Tubing
E.	Washer	AISC 316	Hardened Round Flat Washer
F.	Heavy Hex Nut	ASTM A194 Grade B8M	UNC Series Class 2B fit for 1/4", 3/8", 1/2", 5/8", 3/4", and 1" UN 8 Pitch Series Class 2B fit for 1 1/4"

Stainless Steel Maxi-Bolts
ASTM A193 Grade B8M - Class 2 - Type 316

A.	Conical Nut	1/2" and under ASTM A193 Grade B8M Class 2 5/8" and larger A564 Type 630	UNC Series Class 2B fit for 1/4", 3/8", 1/2", 5/8", 3/4", and 1" UN 8 Pitch Series Class 2B fit for 1 1/4"
B.	Expansion Sleeve	ASTM A213	ERW DOM Tubing
C.	Threaded Stud Bolt	ASTM A193 Grade B8M Class 2 3/4" and under fu = 110,000 psi fy = 95,000 psi 1" fu = 100,000 psi fy = 80,000 psi 1 1/4" fu = 95,000 psi fy = 65,000 psi	UNC Series Class 2B fit for 1/4", 3/8", 1/2", 5/8", 3/4", and 1" UN 8 Pitch Series Class 2B fit for 1 1/4"
D.	Distance Tube	ASTM A213	ERW DOM Tubing
E.	Washer	AISC 316	Hardened Round Flat Washer
F.	Heavy Hex Nut	ASTM A194 Grade B8M Strain Hardened	UNC Series Class 2B fit for 1/4", 3/8", 1/2", 5/8", 3/4", and 1" UN 8 Pitch Series Class 2B fit for 1 1/4"

3.2 Setting Anchor

3.2.1 To set the Maxi-Bolt it is necessary to draw the conical nut on the stud bolt up into the anchor's sleeve. In so doing the expansion sleeve will be forced to move laterally into the undercut portion of the hole and the conical nut will seat fully inside the expansion sleeve. See Figure 4B. This process may be accomplished in one of three ways. (Note: Figure 4A shows hydraulic setting and Figure 6 shows the Hand Bolt Setter.)

3.2.2 Manual Setting

3.2.2.1 Remove nut and washer from anchor and place the end of the anchor stud bolt through the center hole of the Bolt Bushing (from Figure 3). The Bolt Bushing should be oriented so that the 1/16" offset bears against the anchor sleeve. Finger tighten hex nut and washer on anchor bolt assembly.

3.2.2.2 Insert anchor into properly drilled, undercut and cleaned hole.

3.2.2.2.1 Because of close tolerance between conical nut O.D. and hole I.D. it may be necessary to lightly hammer the anchor into the hole:

a. If hammering is necessary, steps shall be employed which will prevent damage to the threads of stud bolt.

3.2.2.3 Depending on the end configuration of the stud bolt, use an allen wrench or adjustable wrench to hold the stud stationary while the heavy hex nut is tightened. The heavy hex nut should be tightened until the conical nut is seated and the expansion sleeve contacts the I.D. of the conical undercut in the concrete. The installer will note a sudden increase in torque required at this point. During the setting operation the orientation of the bolt bushing should be observed and should not be allowed to rotate relative to the concrete surface.

3.2.3 Setting Anchor with Hand Bolt Setting Tool

3.2.3.1 Remove hex nut and washer from Maxi-Bolt. Thread anchor stud into the bottom of the Hand Bolt Setter so that anchor sleeve is firmly in contact with the 1/16" offset of the Bolt Setter's bolt bushing. Place assembly into clean undercut hole. Grasp Hand Bolt Setter handle and turn hex nut in a clockwise direction using a 1 5/8" box end wrench or adjustable wrench. When pin is within 3/16" of the top of slot and the torque required to turn the Hand Bolt Setter hex nut has increased considerably, the anchor is set. Loosen hex nut. Remove Hand Bolt Setter by rotating it in a counterclockwise direction. See Figure 6.

Maxi-Bolt Hand Bolt Setter

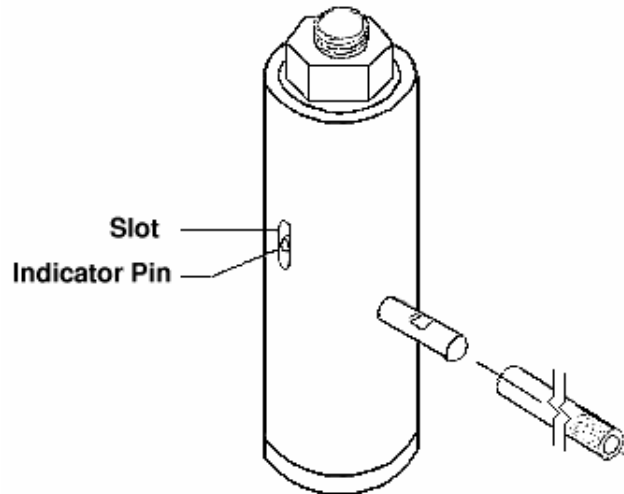

Figure 6

3.2.4 Hydraulic Setting

3.2.4.1 Check to insure that components required for hydraulic setting are present and assembled. See Figure 3.

3.2.4.2 Remove nut and washer from anchor and place the end of the anchor stud bolt through the center hole of the Bolt Bushing. The Bolt Bushing should be oriented so that the 1/16" offset bears against the anchor sleeve. Position the Bolt Bushing in the center of the Base Plate. Then attach draw bar to the stud bolt as shown in Figure 4A.

3.2.4.3 Place the anchor into the drilled and undercut hole so that the Base Plate on the hydraulic cylinder is in contact with the surface of the concrete or attachment. Load the bolt to the values specified in Table III. (Table III gives values for A193 Grade B7 material. For other materials see the Tables for Other Materials.) Remove the Draw Bar, Hydraulic Cylinder, and Bolt Bushing from the anchor.

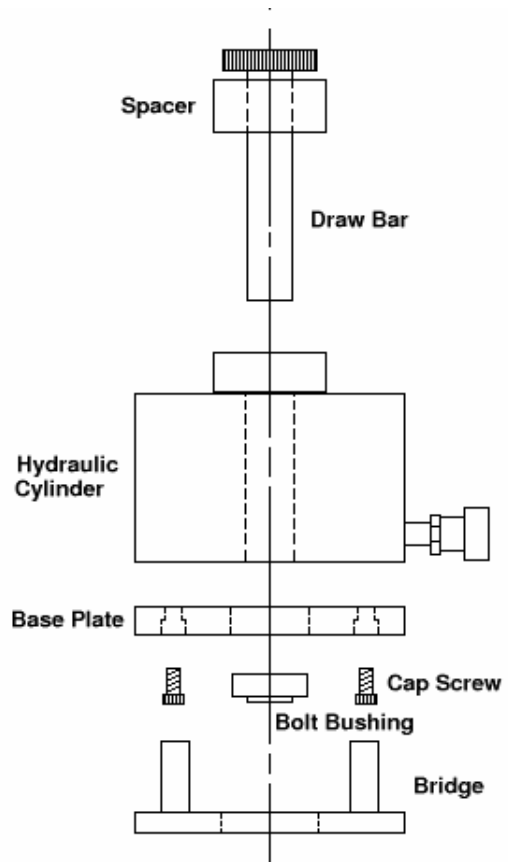

Hydraulic Assembly
Figure 3

Anchor Inset in Hole

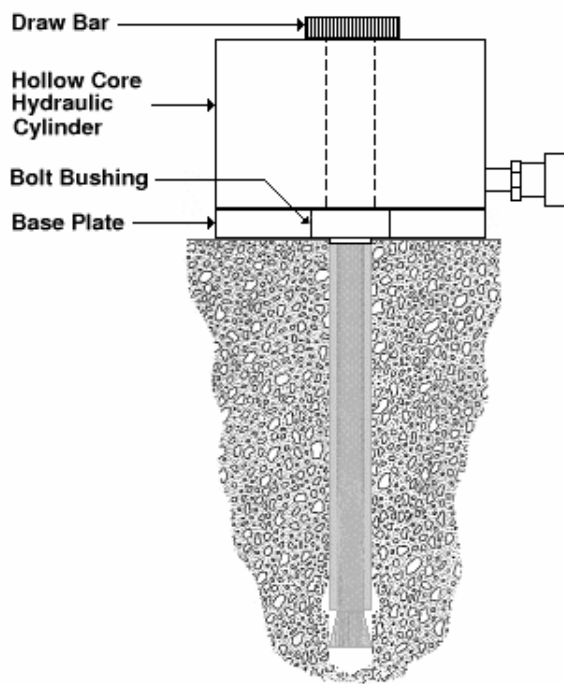

Hydraulic Setting
Figure 4A

Anchor Expanded in Hole

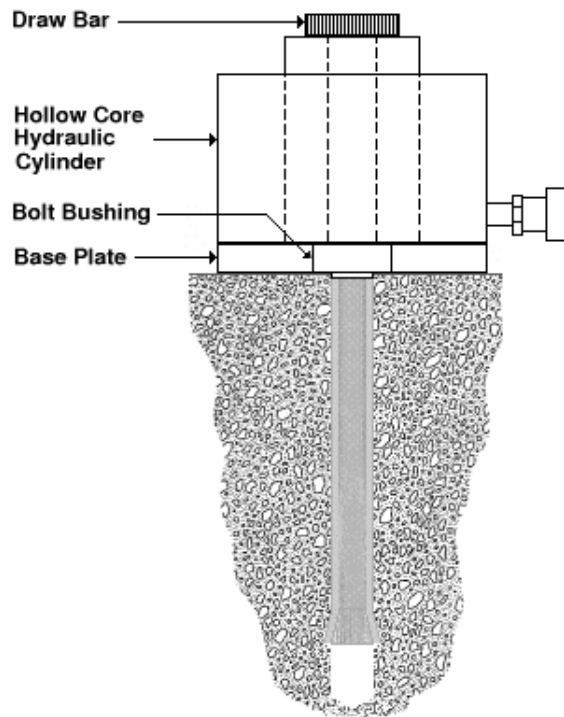

**Hydraulic Setting
Figure 4B**

3.3 Tensioning Anchor

3.3.1 Torque Tensioning

3.3.1.1 Torque anchors to the values specified in Table III. (Table III gives values for A193 Grade B7 material. For other materials see the Tables for Other Materials.) For torquing of 1/4" Maxi-Bolt anchors it is suggested that a click or breakaway type torque wrench be employed to insure that the maximum torque is not exceeded.

3.3.2 Hydraulic Tensioning

3.3.2.1 Replace and finger tighten nut and washer on anchor stud bolt. Place a center pull hydraulic cylinder over the anchor stud and bridge cylinder so that it leaves the hex nut exposed and bears on the concrete surface or attachment around the anchor. Couple to the anchor and tension it to the values specified in Table III. (Table III gives values for A193 Grade B7 material. For other materials see the Tables for Other Materials.) Hold the load on the anchor and tighten down the hex nut to retain the load. Release load and remove the hydraulic cylinder. See Figure 5.

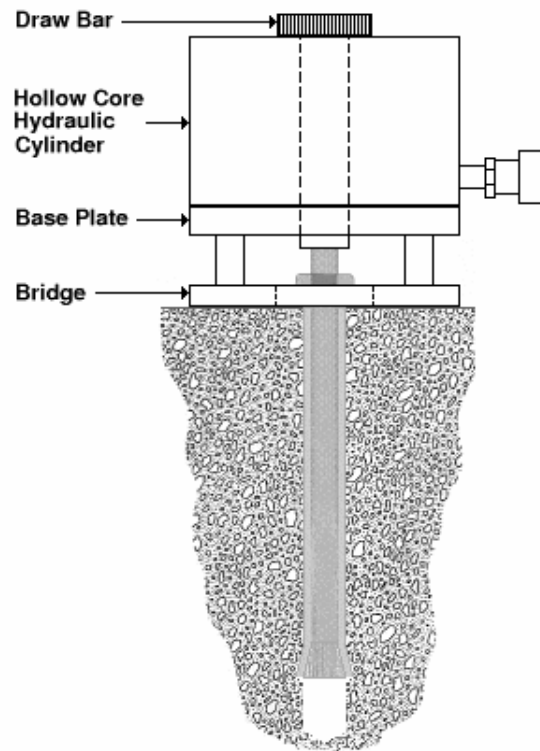

**Hydraulic Tensioning
Figure 5**

TABLE I		
Primary Hole Drill Diameters and Hole Depths		
Nominal Anchor Size	Drill Diameter Maximum	Minimum Hole Depth Anchor Embedment Plus
1/4"	0.530"	1 inch
3/8"	0.655"	1 inch
1/2"	0.778"	1 inch
5/8"	0.975"	1 inch
3/4"	1.172"	1 1/2 inch
1"	1.690"	2 inches
1 1/4"	2.065"	2 inches
1/2" Heavy	0.845"	1 inch

TABLE II					
Undercutting Tool Diameters & Tolerances					
Nominal Anchor Size	Diameter A	Diameter B	Tolerance	Diameter G	Tolerance
1/4"	0.500"	0.750"	+0.020" -.060"	0.625"	+0.001" -.001"
3/8"	0.625"	0.875"	+0.020" -.060"	0.750"	+0.001" -.001"
1/2"	0.709"	0.949"	+0.010" -.030"	N/A	N/A
5/8"	0.905"	1.176"	+0.010" -.030"	N/A	N/A
3/4"	1.102"	1.550"	+0.010" -.040"	N/A	N/A
1"	1.625"	2.275"	+0.010" -.050"	N/A	N/A
1 1/4"	2.000"	2.770"	+0.010" -.060"	N/A	N/A
1/2" Heavy	0.812"	1.120"	+0.010" -.030"	N/A	N/A

TABLE III (RCH Data) with data for RCH series hydraulic cylinders					
Torque and Load Values for A193 Grade B7 Material					
Nominal Anchor Size	Tensioning Torque (Ft. Lb.)	Setting Load (Pounds) (A) .50 Fy - .525 Fy	(Setting) Hydraulic Gage Reading (PSI)	Tensioning Load (Pounds) .81 Fy - .85 Fy	(Tension) Hydraulic Gage Reading (PSI)
1/4"	9 - 12	1,680 - 1,764	232 - 244 *	2,722 - 2,858	377 - 395 *
3/8"	40 - 44	4,095 - 4,300	567 - 595 *	6,634 - 6,966	918 - 964 *
1/2"	80 - 90	7,455 - 7,828	1,032 - 1,084 *	12,077 - 12,681	1,672 - 1,756 *
5/8"	180 - 200	11,865 - 12,458	1,643 - 1,725 *	19,221 - 20,182	2,662 - 2,795 *
3/4"	340 - 360	17,535 - 18,412	2,428 - 2,550 *	28,406 - 29,826	3,934 - 4,131 *
1"	640 - 660	31,815 - 33,406	2,497 - 2,622**	51,540 - 54,117	4,045 - 4,247 **
1 1/4"	1,460 - 1,490	52,485 - 55,109	4,119 - 4,325 **	85,024 - 89,275	6,673 - 7,007 **

All torque values based upon Maxi-Bolts furnished with electrozinc plating to Federal Specification QQ-Z-325c Type II Class 3

(A) If desired, this range may extend from .50 Fy to .81 Fy.

* Determined by dividing load pounds by 7.22 square inches (Drillco supplied RCH-302 Hydraulic System)

** Determined by dividing load pounds by 12.74 square inches (Drillco supplied RCH-603 Hydraulic System)

TABLE III (RC Data) with data for RC series hydraulic cylinders					
Torque and Load Values for A193 Grade B7 Material					
Nominal Anchor Size	Tensioning Torque (Ft. Lb.)	Setting Load (Pounds) (A) .50 Fy - .525 Fy	(Setting) Hydraulic Gage Reading (PSI)	Tensioning Load (Pounds) .81 Fy - .85 Fy	(Tension) Hydraulic Gage Reading (PSI)
1/4"	9 - 12	1,680 - 1,764	257 - 270 *	2,722 - 2,858	416 - 437 *
3/8"	40 - 44	4,095 - 4,300	627 - 658 *	6,634 - 6,966	1,015 - 1,067 *
1/2"	80 - 90	7,455 - 7,828	1,142 - 1,199 *	12,077 - 12,681	1,850 - 1,942 *
5/8"	180 - 200	11,865 - 12,458	1,817 - 1,908 *	19,221 - 20,182	2,943 - 3,091 *
3/4"	340 - 360	17,535 - 18,412	2,685 - 2,820 *	28,406 - 29,826	4,350 - 4,568 *
1"	640 - 660	31,815 - 33,406;	2,400 - 2,521**	51,540 - 54,117	3,890 - 4,085 **
1 1/4"	1,460 - 1,490	52,485 - 55,109	3,960 - 4,160 **	85,024 - 89,275	6,415 - 6,740 **

All torque values based upon Maxi-Bolts furnished with electrozinc plating to Federal Specification QQ-Z-325c Type II Class 3

(A) If desired, this range may extend from .50 Fy to .81 Fy.

* Determined by dividing load pounds by 6.53 square inches (Drillco supplied RC-302 Hydraulic System)

** Determined by dividing load pounds by 13.25 square inches (Drillco supplied RC-603 Hydraulic System)

TABLE III (ASTM A36 Material) with data for RCH-Series Hydraulic Cylinders			
Torque and Load Values for A36 Material (Reduced Edge Distances Require Lower Values)			
Nominal Anchor Size	Tensioning Torque (Ft. Lb.)	Setting and Tensioning Load (Pounds) .81 Fy - .85 Fy	Hydraulic Gage Reading (PSI)
3/8"	18 - 20	2,275 - 2,385	315 - 330 *
1/2"	35 - 40	4,140 - 4,345	575 - 600 *
5/8"	80 - 85	6,590 - 6,915	915 - 960 *
3/4"	130 - 140	9,740 - 10,220	1,350 - 1,415 *
1"	420 - 440	17,670 - 18,545	1,390 - 1,455 **
1 1/4"	610 - 630	29,160 - 30,600	2,290 - 2,400 **

All torque values based upon Maxi-Bolts furnished with electrozinc plating to Federal Specification QQ-Z-325c Type II Class 3

* Determined by dividing load pounds by 7.22 square inches (Drillco supplied RCH-302 Hydraulic System). For other hydraulic cylinders, divide the Setting Load by the effective cylinder cross section as given by the cylinder manufacturer to obtain the appropriate gage readings.

** Determined by dividing load pounds by 12.74 square inches (Drillco supplied RCH-603 Hydraulic System). For other hydraulic cylinders, divide the Setting Load by the effective cylinder cross section as given by the cylinder manufacturer to obtain the appropriate gage readings.

TABLE III (ASTM A36 Material) with data for RC-Series Hydraulic Cylinders			
Torque and Load Values for A36 Material (Reduced Edge Distances Require Lower Values)			
Nominal Anchor Size	Tensioning Torque (Ft. Lb.)	Setting and Tensioning Load (Pounds) .81 Fy - .85 Fy	Hydraulic Gage Reading (PSI)
3/8"	18 - 20	2,275 - 2,385	350 - 365 *
1/2"	35 - 40	4,140 - 4,345	635 - 665 *
5/8"	80 - 85	6,590 - 6,915	1,010 - 1,060 *
3/4"	130 - 140	9,740 - 10,220	1,490 - 1,565 *
1"	420 - 440	17,670 - 18,545	1,335 - 1,400 **
1 1/4"	610 - 630	29,160 - 30,600	2,200 - 2,300 **

All torque values based upon Maxi-Bolts furnished with electrozinc plating to Federal Specification QQ-Z-325c Type II Class 3

* Determined by dividing load pounds by 6.53 square inches (Drillco supplied RC-302 Hydraulic System). For other hydraulic cylinders, divide the Setting Load by the effective cylinder cross section as given by the cylinder manufacturer to obtain the appropriate gage readings.

** Determined by dividing load pounds by 13.25 square inches (Drillco supplied RC-603 Hydraulic System). For other hydraulic cylinders, divide the Setting Load by the effective cylinder cross section as given by the cylinder manufacturer to obtain the appropriate gage readings.

TABLE III (ASTM A193 B8 (Type 304) and B8M (Type 316) - Class 1 Material) with data for RCH-Series Hydraulic Cylinders			
Torque and Load Values for A193 B8 (Type 304) and B8M (Type 316) - Class 1 Stainless Steel Material (Reduced Edge Distances Require Lower Values)			
Nominal Anchor Size	Tensioning Torque (Ft. Lb.)	Setting and Tensioning Load (Pounds) .81 Fy - .85 Fy	Hydraulic Gage Reading (PSI)
3/8"	15 - 18	1,895 - 1,990	260 - 275 *
1/2"	30 - 35	3,450 - 3,620	475 - 500 *
5/8"	65 - 70	5,490 - 5,765	760 - 800 *
3/4"	105 - 115	8,115 - 8,515	1,125 - 1,180 *
1"	300 - 320	14,725 - 15,455	1,155 - 1,215 **
1 1/4"	420 - 440	24,300 - 25,500	1,905 - 2,000 **

All torque values based upon Maxi-Bolts furnished with electrozinc plating to Federal Specification QQ-Z-325c Type II Class 3

* Determined by dividing load pounds by 7.22 square inches (Drillco supplied RCH-302 Hydraulic System). For other hydraulic cylinders, divide the Setting Load by the effective cylinder cross section as given by the cylinder manufacturer to obtain the appropriate gage readings.

** Determined by dividing load pounds by 12.74 square inches (Drillco supplied RCH-603 Hydraulic System). For other hydraulic cylinders, divide the Setting Load by the effective cylinder cross section as given by the cylinder manufacturer to obtain the appropriate gage readings.

TABLE III (ASTM A193 B8 (Type 304) and B8M (Type 316) - Class 1 Material) with data for RC-Series Hydraulic Cylinders			
Torque and Load Values for A193 B8 (Type 304) and B8M (Type 316) - Class 1 Stainless Steel Material (Reduced Edge Distances Require Lower Values)			
Nominal Anchor Size	Tensioning Torque (Ft. Lb.)	Setting and Tensioning Load (Pounds) .81 Fy - .85 Fy	Hydraulic Gage Reading (PSI)
3/8"	15 - 18	1,895 - 1,990	290 - 305 *
1/2"	30 - 35	3,450 - 3,620	530 - 555 *
5/8"	65 - 70	5,490 - 5,765	840 - 880 *
3/4"	105 - 115	8,115 - 8,515	1,240 - 1,305 *
1"	300 - 320	14,725 - 15,455	1,110 - 1,165 **
1 1/4"	420 - 440	24,300 - 25,500	1,835 - 1,925 **

All torque values based upon Maxi-Bolts furnished with electrozinc plating to Federal Specification QQ-Z-325c Type II Class 3

* Determined by dividing load pounds by 6.53 square inches (Drillco supplied RC-302 Hydraulic System). For other hydraulic cylinders, divide the Setting Load by the effective cylinder cross section as given by the cylinder manufacturer to obtain the appropriate gage readings.

** Determined by dividing load pounds by 13.25 square inches (Drillco supplied RC-603 Hydraulic System). For other hydraulic cylinders, divide the Setting Load by the effective cylinder cross section as given by the cylinder manufacturer to obtain the appropriate gage readings.

TABLE III (ASTM A193 B8 (Type 304) - Class 2 Material) with data for RCH-Series Hydraulic Cylinders			
Torque and Load Values for A193 B8 (Type 304) - Class 2 Stainless Steel Material (Reduced Edge Distances Require Lower Values)			
Nominal Anchor Size	Tensioning Torque (Ft. Lb.)	Setting and Tensioning Load (Pounds) .81 Fy - .85 Fy	Hydraulic Gage Reading (PSI)
3/8"	40 - 44	6,320 - 6,630	875 - 920 *
1/2"	80 - 90	11,500 - 12,070	1,590 - 1,670 *
5/8"	180 - 200	18,305 - 19,210	2,535 - 2,660 *
3/4"	340 - 360	27,055 - 28,390	3,750 - 3,930 *
1"	410 - 430	39,270 - 41,208	3,080 - 3,235 **
1 1/4"	900-920	52,650 - 55,250	4,130 - 4,335 **

All torque values based upon Maxi-Bolts furnished with electrozinc plating to Federal Specification QQ-Z-325c Type II Class 3

* Determined by dividing load pounds by 7.22 square inches (Drillco supplied RCH-302 Hydraulic System). For other hydraulic cylinders, divide the Setting Load by the effective cylinder cross section as given by the cylinder manufacturer to obtain the appropriate gage readings.

** Determined by dividing load pounds by 12.74 square inches (Drillco supplied RCH-603 Hydraulic System). For other hydraulic cylinders, divide the Setting Load by the effective cylinder cross section as given by the cylinder manufacturer to obtain the appropriate gage readings.

TABLE III (ASTM A193 B8 (Type 304) - Class 2 Material) with data for RC-Series Hydraulic Cylinders			
Torque and Load Values for A193 B8 (Type 304) - Class 2 Stainless Steel Material (Reduced Edge Distances Require Lower Values)			
Nominal Anchor Size	Tensioning Torque (Ft. Lb.)	Setting and Tensioning Load (Pounds) .81 Fy - .85 Fy	Hydraulic Gage Reading (PSI)
3/8"	40 - 44	6,320 - 6,630	965 - 1,015 *
1/2"	80 - 90	11,500 - 12,070	1,760 - 1,850 *
5/8"	180 - 200	18,305 - 19,210	2,800 - 2,940 *
3/4"	340 - 360	27,055 - 28,390	4,140 - 4,345 *
1"	410 - 430	39,270 - 41,208	2,965 - 3,110 **
1 1/4"	900-920	52,650 - 55,250	3,975 - 4,170 **

All torque values based upon Maxi-Bolts furnished with electrozinc plating to Federal Specification QQ-Z-325c Type II Class 3

* Determined by dividing load pounds by 6.53 square inches (Drillco supplied RC-302 Hydraulic System). For other hydraulic cylinders, divide the Setting Load by the effective cylinder cross section as given by the cylinder manufacturer to obtain the appropriate gage readings.

** Determined by dividing load pounds by 13.25 square inches (Drillco supplied RC-603 Hydraulic System). For other hydraulic cylinders, divide the Setting Load by the effective cylinder cross section as given by the cylinder manufacturer to obtain the appropriate gage readings.

TABLE III (ASTM A193 B8M (Type 316) - Class 2 Material) with data for RCH-Series Hydraulic Cylinders			
Torque and Load Values for A193 B8M (Type 316) - Class 2 Stainless Steel Material (Reduced Edge Distances Require Lower Values)			
Nominal Anchor Size	Tensioning Torque (Ft. Lb.)	Setting and Tensioning Load (Pounds) .81 Fy - .85 Fy	Hydraulic Gage Reading (PSI)
3/8"	38 - 42	6,000 - 6,300	830 - 875 *
1/2"	75 - 85	10,925 - 11,465	1,510 - 1,590 *
5/8"	170 - 190	17,390 - 18,250	2,300 - 2,525 *
3/4"	310 - 330	25,700 - 26,970	3,560 - 3,735 *
1"	410 - 430	39,270 - 41,208	3,080 - 3,235 **
1 1/4"	900 - 920	52,650 - 55,250	4,130 - 4,335 **

All torque values based upon Maxi-Bolts furnished with electrozinc plating to Federal Specification QQ-Z-325c Type II Class 3

* Determined by dividing load pounds by 7.22 square inches (Drillco supplied RCH-302 Hydraulic System). For other hydraulic cylinders, divide the Setting Load by the effective cylinder cross section as given by the cylinder manufacturer to obtain the appropriate gage readings.

** Determined by dividing load pounds by 12.74 square inches (Drillco supplied RCH-603 Hydraulic System). For other hydraulic cylinders, divide the Setting Load by the effective cylinder cross section as given by the cylinder manufacturer to obtain the appropriate gage readings.

TABLE III (ASTM A193 B8M (316) - Class 2 Material) with data for RC-Series Hydraulic Cylinders			
Torque and Load Values for A193 B8M (316) - Class 2 Stainless Steel Material (Reduced Edge Distances Require Lower Values)			
Nominal Anchor Size	Tensioning Torque (Ft. Lb.)	Setting and Tensioning Load (Pounds) .81 Fy - .85 Fy	Hydraulic Gage Reading (PSI)
3/8"	38 - 42	6,000 - 6,300	920 - 965 *
1/2"	75 - 85	10,925 - 11,465	1,675 - 1,755 *
5/8"	170 - 190	17,390 - 18,250	2,665 - 2,795 *
3/4"	310 - 330	25,700 - 26,970	3,935 - 4,130 *
1"	410 - 430	39,270 - 41,208	2,965 - 3,110 **
1 1/4"	900 - 920	52,650 - 55,250	3,975 - 4,170 **

All torque values based upon Maxi-Bolts furnished with electrozinc plating to Federal Specification QQ-Z-325c Type II Class 3

* Determined by dividing load pounds by 6.53 square inches (Drillco supplied RC-302 Hydraulic System). For other hydraulic cylinders, divide the Setting Load by the effective cylinder cross section as given by the cylinder manufacturer to obtain the appropriate gage readings.

** Determined by dividing load pounds by 13.25 square inches (Drillco supplied RC-603 Hydraulic System). For other hydraulic cylinders, divide the Setting Load by the effective cylinder cross section as given by the cylinder manufacturer to obtain the appropriate gage readings.